

OCDRIVESHAFT.COM

SAMPLE FORM

ENTER SPECS FOR CUSTOM SHAFT
DOUBLE-CHECK SPECS BEFORE PURCHASE
PURCHASE IS ALLOWED AFTER COMPLETING FORM

Driveshaft Build Form: 1330 Series, 2.50" Heavy, Transmission Slip Yoke to U-joint

Fill out form to build your driveshaft

Contact information:

First Name Last Name

Email

Phone

Area Code Phone Number

Contact information is used for automated confirmation email.

Next

Driveshaft Build Form: 1330 Series, 2.50" Heavy, Transmission Slip Yoke to U-joint

Required measurements and information

This form will help you gather the measurements necessary to build a driveshaft for your application.

IMPORTANT NOTES:

Always measure driveshaft length with vehicle suspension at ride height.

We measure everything in inches.

When measuring anything under 6 inches, use a 6-inch scale or calipers, avoid using a tape measure.

Measurement Guide:

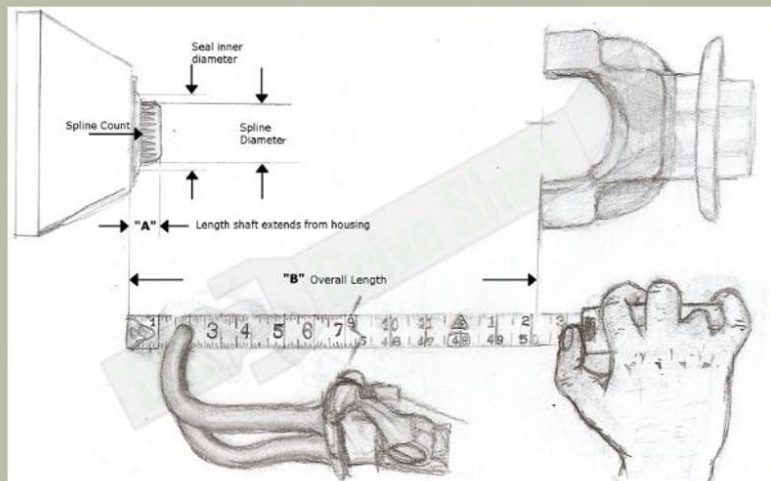

NOTE: Maximum Overall Length for 2.5" Shaft is 45.0". WHY? [Click HERE](#) to find out.

Enter dimensions in fields:

Dimensions are measured in inches and can be entered as decimals (eg. 0.75 or 20.125)

A: Length shaft extends from housing

Enter a number between 0.000 and 10.000

Valid range (0.000" to 10.000")

B: Overall Length

Enter a length between 8.000 and 45.000

Valid range for 2.5" shafts (8.000" to 45.000") Need a longer shaft? Go back and choose form for 3" tubing.

Shaft dimensions are entered in these fields.

Go Back

Next

Driveshaft Build Form: 1330 Series, 2.50" Heavy, Transmission Slip Yoke to U-joint

Select Slip Yoke

Make selection from list below

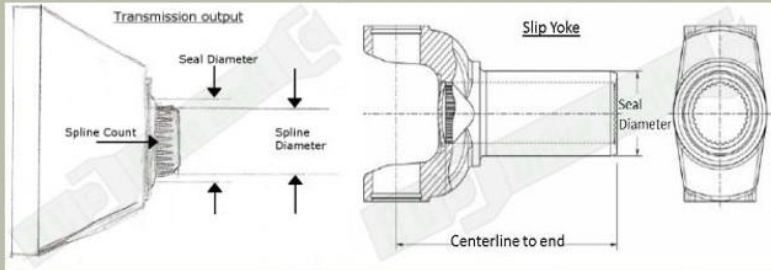

Note: GM TH400 with threaded hole in output shaft is "Fixed Yoke" transmission and requires a .550" counterbored slip yoke, only available in Sonnax 1350 Mega Series.

Slip Yoke choices are displayed in 2 categories:

Standard: Slip yokes from Spicer, Neapco and PTI are included in the driveshaft price. (Includes Ford, GM)

Sonnax Chrome Moly (add \$80): Forged Chromoly slip yokes are available for popular muscle cars.

- Standard Slip Yoke
- Sonnax Chrome Moly (Add \$80)

<input checked="" type="radio"/>	Spline count	Spline Diameter	Centerline to end	Seal Diameter	Possible applications
<input type="radio"/>	XX	X.XXX	X.XXX	X.XXX	Grampa's roadmaster

Standard	<input checked="" type="radio"/>	25	1.113	6.860	1.374	Ford Ranger
	<input checked="" type="radio"/>	28	1.220	5.906	1.500	Ford C4
	<input checked="" type="radio"/>	31	1.390	6.000	1.688	Ford C6
	<input checked="" type="radio"/>	27	1.176	6.760	1.502	GM 700R4 Vented, 4L60E
	<input checked="" type="radio"/>	27	1.176	5.470	1.502	GM TH350 Standard
	<input checked="" type="radio"/>	28	1.220	6.630	1.597	Ford 4R70W 95 up
	<input checked="" type="radio"/>	32	1.378	7.340	1.885	GM TH400, 4L80E + tcase (ni plated)
	<input checked="" type="radio"/>	32	1.378	6.760	1.885	GM TH400, 4L80E Full spline, 1983-96 GM trucks/SUV's
	<input checked="" type="radio"/>	32	1.378	4.960	1.885	TH400 Corvette / Strap style
	<input checked="" type="radio"/>	31	1.390	7.000	1.885	Ford tcase Borg Warner
<input checked="" type="radio"/>	31	1.378	7.940	1.885	GM TH400, (Counter Bore .220")	
Sonnax Chrome Moly	<input checked="" type="radio"/>	28	1.220	5.906	1.500	Ford C4
	<input checked="" type="radio"/>	31	1.390	6.000	1.688	Ford C6
	<input checked="" type="radio"/>	27	1.176	6.760	1.502	GM 700R4 Vented, 4L60E
	<input checked="" type="radio"/>	27	1.176	5.470	1.502	GM TH350 Standard
	<input checked="" type="radio"/>	28	1.220	6.630	1.597	Ford 4R70W 95 up
	<input checked="" type="radio"/>	32	1.378	6.760	1.885	GM TH400, 4L80E Full spline, 1983-96 GM trucks/SUV's
	<input checked="" type="radio"/>	31	1.390	7.000	1.885	Ford tcase Borg Warner

Choose correct slip yoke for your application

Go Back

Next

Driveshaft Build Form: 1330 Series, 2.50" Heavy, Transmission Slip Yoke to U-joint

Determine pinion yoke style and u joint series

Make selection for pinion yoke style and u joint series below

Select pinion yoke style

- With locating tabs (outside lockup)
- Without locating tabs (inside lockup)

Select pinion yoke style and u-joint series

Outside lockup style yoke

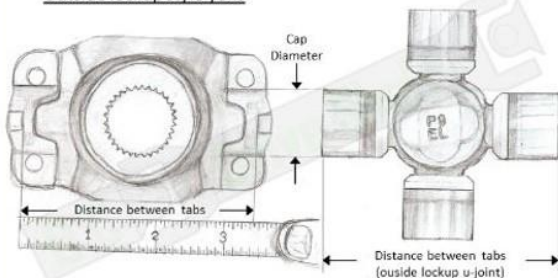

Outside Locating Tabs				
Series	Cap Diameter Decimal	Cap Diameter Fractional	Dimension Between Tabs	Notes
1330	1.063"	1-1/16"	3.625"	Spicer Solid Body
1330 Ford	1.125"	1-1/8"	3.625"	Spicer Solid Body
1350	1.188"	1-3/16"	3.625"	Greasable

Inside lockup style yoke

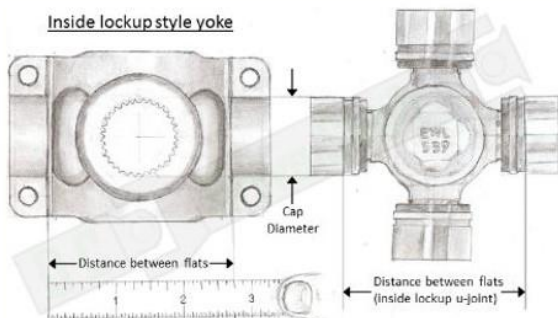

Inside Locating Tabs				
Series	Cap Diameter Decimal	Cap Diameter Fractional	Dimension Between Tabs	Notes
3R	1.125"	1-1/8"	2.556"	Spicer Solid Body
7290	1.126"	1-1/8"	2.622"	Spicer Solid Body

[Go Back](#)

[Next](#)

OCDRIVESHAFT.COM

Driveshaft Build Form: 1330 Series, 2.50" Heavy, Transmission Slip Yoke to U-joint

Your Name

The final step to complete this form is [Verify the information below](#):

Email: your@name.com

Phone number: 555 555-1234

Stickout length (inches): .625

Overall Length (inches): 40.125

Slip yoke type: Standard Slip Yoke

Slip yoke application: 25 1.113 0.800 1.374 Ford Ranger

Outside Lookup U-joint series: 1.082" cap, 3.625" between tabs (1330 series)

The data collected for a custom: 1330 series, 2.5" HEAVY driveshaft (transmission slip yoke to U-joint)



(generic image represents style of driveshaft specified by this form)

The information is correct - [Continue and Purchase](#)

The information is not correct - [Go Back](#)

[Continue and Purchase](#)

[Go Back](#)

Verify all entries are correct before submitting form.
Entries may be changed by going back.

“Continue and Purchase” sends an email with your driveshaft specs and directs you to the checkout to complete the purchase of your custom driveshaft.

Driveshaft Build Form: 1330 Series, 2.50" Heavy, Transmission Slip Yoke to U-joint

Your Name

Thank you for choosing OC Driveshaft.

A copy of your Custom Build Form has been sent to our technicians and to your email for reference.

To complete your order, [Click the link below to purchase your custom driveshaft.](#)

[Purchase Custom Shaft](#)

“Purchase Custom Shaft” directs you to the Online Store to finalize your purchase.



[Register](#) | [Login](#)

[HOME](#) [DRIVESHAFTS](#) [SHAFT FACTS](#) [ROYAL PURPLE](#) [STORE](#) [CONTACT US AND INFO](#)

Supreme Series 2.5" Heavy Driveshaft, 1330 Series, Standard Slip Yoke



Supreme Series 2.5" Heavy Driveshaft, 1330 Series, Standard Slip Yoke

- Custom 2.5" 1330 Heavy Driveshaft
- Built to specs from Custom Build Form
- Includes selected Slip Yoke

Price: USD \$390.00

Quantity: *

[Add to cart](#)

“Add to cart” and complete secure checkout.

Supreme Series Heavy Driveshafts

Supreme Series Heavy Driveshafts are built to meet the demands of higher powered muscle cars.

Heavy driveshafts use thicker wall .083" steel DOM tubing and Spicer 1330 solid body U-joints.

All transmission slip yokes are equipped with 1330 series Spicer solid body U-joints that can handle up to 699 hp.

All Super Series Driveshafts are precision high speed balanced on our Hines DL-500 driveline balancer.